

High order modes suppression in large mode area active fibers by controlling the radial distribution of the rare earth dopant.

Mircea Hotoleanu¹, Mikko Söderlund¹, Dahv Kliner², Jeffrey Koplow², Simo Tammela¹, Valery Philippov¹

¹ Liekki Oy, ² Sandia National Laboratories

Introduction

Many high power fiber laser applications require doped fibers having large mode area but still working in the single mode regime. The most common techniques to keep a large mode area fiber in the single mode regime are to reduce the core numerical aperture, to strip the high order modes by coiling the fiber, to launch only a single transverse mode, or to use photonic crystal fibers. All these methods have limits and disadvantages.

In this paper we demonstrate by simulation the effectiveness of another method to suppress the high order modes in large mode area active fibers by optimizing the rare earth dopant concentration across the core while keeping the step index structure of the core of the fiber. This method was not previously employed because the traditional doped fiber manufacturing technologies do not have the required capability to radially control the dopant concentration. However, Direct Nanoparticle Deposition (DND) can be used to manufacture large mode area fibers having any radial distribution of active element concentration and any refractive index profile. Thus, DND fibers can be designed to benefit from this high order mode suppression technique.

The simulation results presented in this paper have been obtained using Liekki Application Designer v3.1, a software simulator for fiber lasers and amplifiers. The signal, pump, and bi-directional amplified spontaneous emission (ASE) powers are calculated along the double-clad fiber. The signal is assumed to propagate in the multimode regime, where all supported modes are equally excited. The pump is coupled in the inner cladding of the double-clad fiber. Only the fundamental mode (LP₀₁) is considered for ASE power propagation. This approximation is acceptable in this case because the signal power is relatively high. Also, the fiber is assumed to be straight. This calculation does not take into account mode distortion caused by fiber bending.

Setup description

To evaluate the influence of the doping profile over the modal composition of the output signal, we have used the setup presented in Figure 1. The doped fiber has a double-clad structure with a 25μm core diameter and 125μm inner-cladding diameter. The core has a step refractive index profile with NA=0.06. We have considered two types of dopants, ytterbium and erbium, and four doping

structures: 12.5um radius (unconfined), 10um radius, 7.5um radius (all flat doped), and 12.5um radius parabolic doping.

For the ytterbium doped fiber, the dopant concentration in the center of the core was 1.5×10^{27} ions/m³. The pump source provides 10W at 920nm. The signal source wavelength is 1060nm. For erbium doped fiber, the dopant concentration in the center of the core was 4×10^{25} Yb ions/m³. The pump source provides 10W at 980nm. The signal source wavelength is 1550nm. The fiber lengths have been adjusted from case to case to generate an output power close to the maximum possible in each configuration.

During simulation all guided modes at the signal wavelength have been calculated, and it was assumed that each mode is excited at the fiber input with 100mW power at the corresponding wavelength. This approach was not meant to simulate a particular device but was chosen to evaluate the competition between modes during propagation.

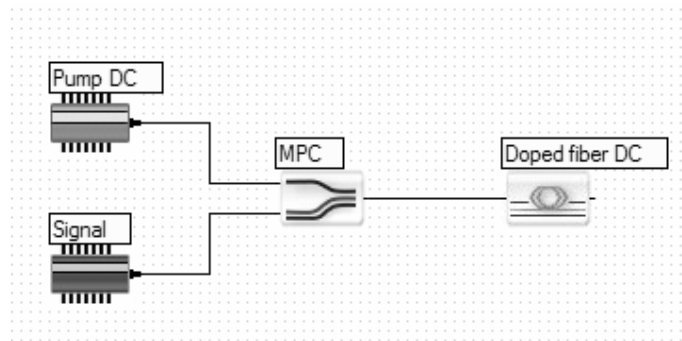

Figure 1: The setup used in simulations

Results with an ytterbium doped fiber

A 25um core with NA=0.06 at 1060nm supports six guided modes: LP₀₁, LP₁₁ (two helical polarities), LP₀₂ and LP₂₁ (two helical polarities) – see Figure 2. The propagation of these modes along the ytterbium doped fiber is presented in Figure 3. The curves for LP₁₁ and LP₂₁ show the sum of the sine and cosine variants of the corresponding modes.

In the non-confined fiber (Figure 3a) the fundamental mode LP₀₁ output has 1.5W, while the LP₁₁ output has 2.6W and the LP₂₁ output has 2W. In total, there is 5.3W output power in high order modes. As a result, the output beam is far from a Gaussian shape (see Figure 4a).

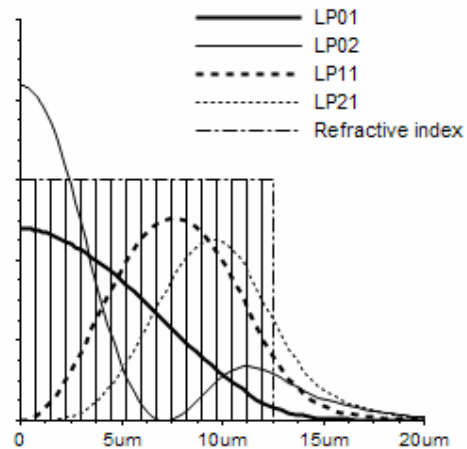

Figure 2: The normalized intensity modal distribution at 1060nm for 12.5um core radius with NA=0.06

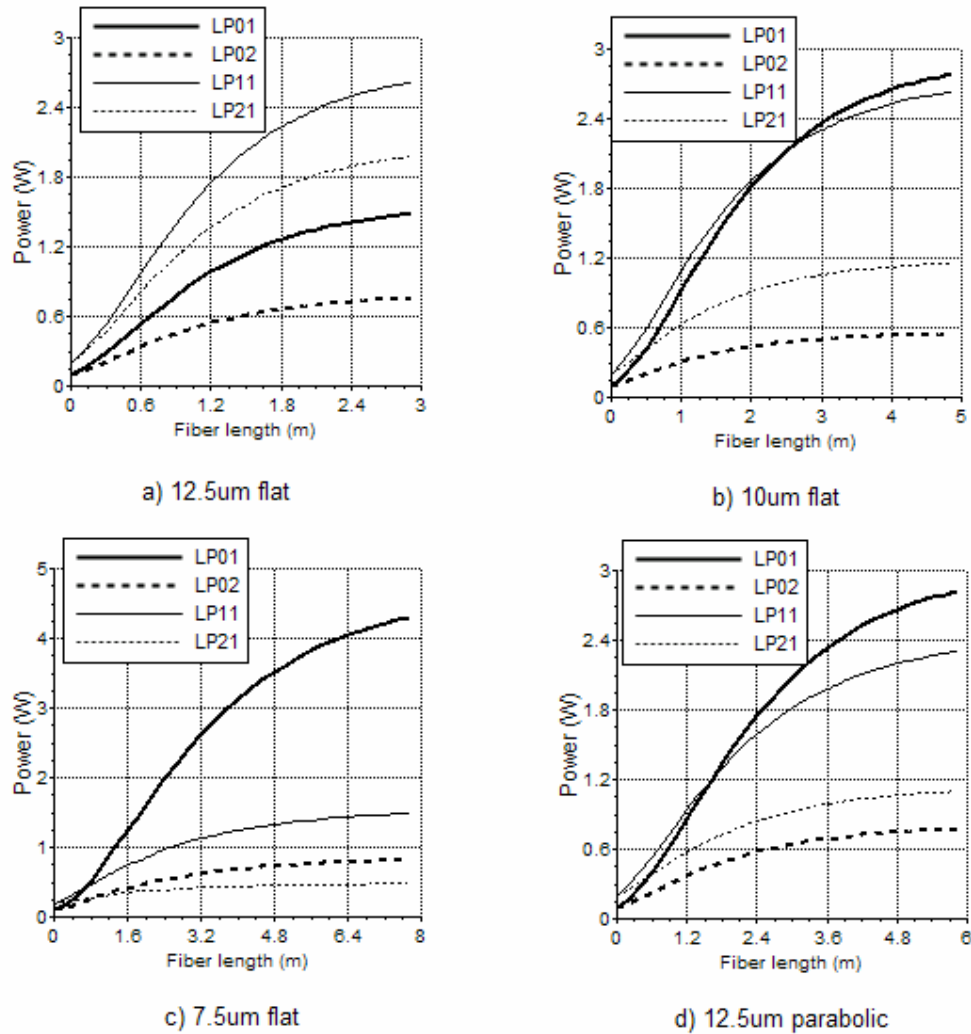

Figure 3: Propagation of individual modes in the ytterbium doped fiber with various dopant distributions

The confinement of the rare earth dopant favors the modes having more power concentrated in the center of the core (especially LP_{01}). This effect can be seen in Figures 3b, c, and d. The ratio between the LP_{01} output power and the total higher order mode output power rises from 0.49 (unconfined doping) to 0.64 (10 um confined doping), 1.55 (7.5 um confined doping), and 0.67 (parabolic doping). The doping confinement effect on the output beam profile (near field) can be seen in Figure 4.

One can see that the confinement has a stronger effect on LP_{11} and LP_{21} than on LP_{02} . However, having a high central peak, LP_{02} has a less detrimental effect on the shape of the output beam for some applications.

The benefit of the confinement is balanced by the drawback of a longer doped fiber and/or a higher dopant concentration. Tuning the rare earth doping profile and choosing the highest dopant concentration available can further optimize the design. Designing such fibers is not just a theoretical exercise. DND can provide both dopant profiling and, currently, the highest dopant concentration.

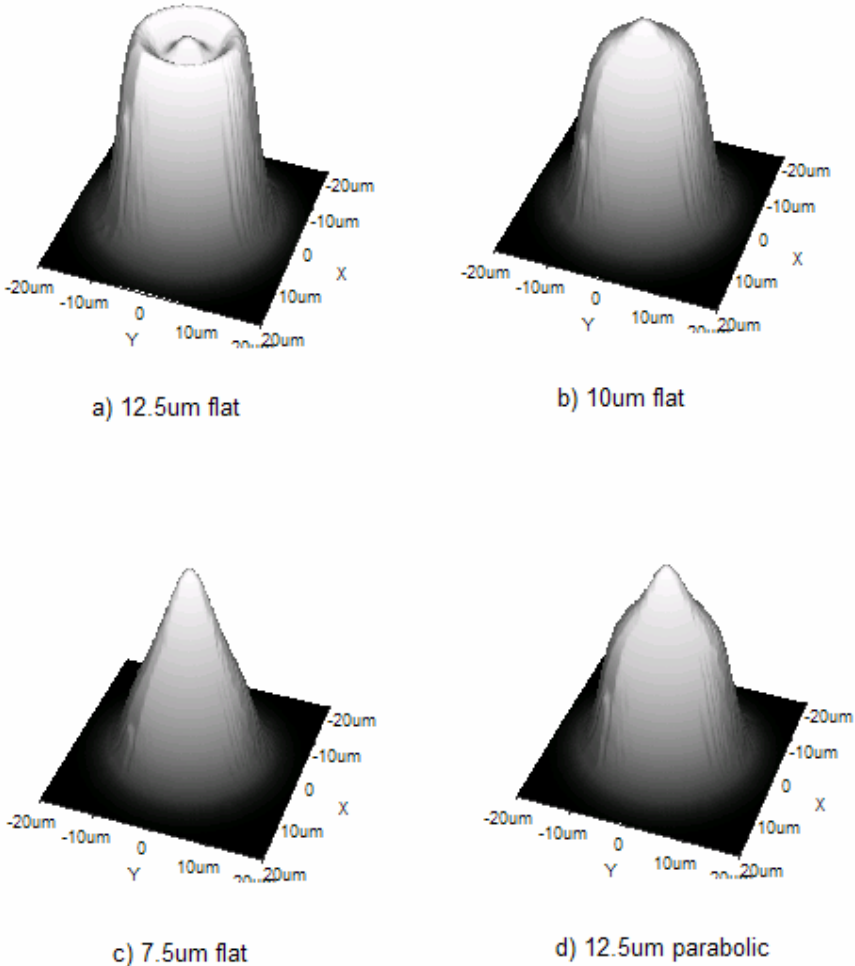

Figure 4: Profiles of the output beams for the ytterbium doped fiber

Results with an erbium doped fiber

A 25 μm core with $\text{NA}=0.06$ at 1550nm supports three guided modes: LP_{01} and LP_{11} (two helical polarities). The normalized intensity modal distributions at azimuth angle 0 are presented in Figure 5. The propagation of these modes along the erbium doped fiber is presented in Figure 6. The curve for LP_{11} shows the sum of the sine and cosine variants.

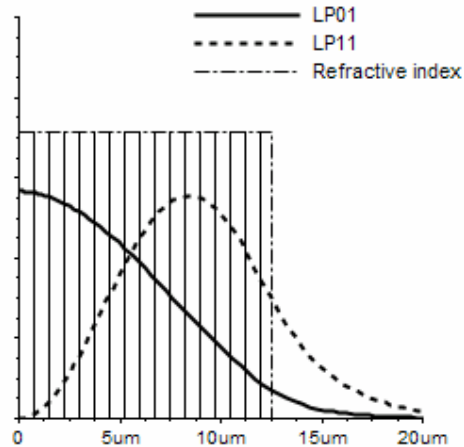
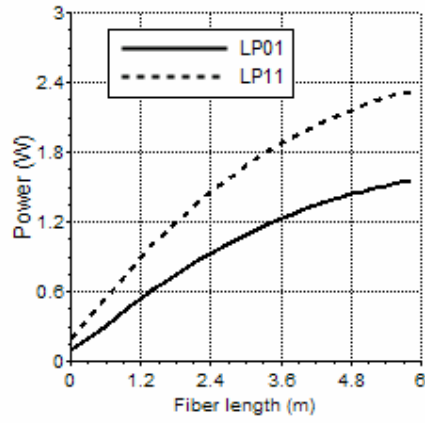

Figure 5: The normalized intensity modal distribution at 1550 nm for 12.5 μm core radius with $\text{NA}=0.06$

In the non-confined fiber (Figure 6a) the fundamental mode LP_{01} output has 1.5W and LP_{11} output has 2.6W. As a result, the output beam shape is far from a Gaussian (see Figure 7a). The confinement effect is analyzed in the same cases as for ytterbium doped fiber.

The ratio between LP_{01} output power and LP_{11} output power rises from 0.67 (unconfined doping) to 1.40 (10 μm confinement), 3.21 (7.5 μm confinement), and 1.42 (parabolic doping). One can see that these numbers are significantly higher than those for ytterbium doped fiber due to the lower number of high order modes (lower V-number). Also the output beam shape looks much closer to a Gaussian shape (Figure 7).

The parabolic doping has a less strong effect when compared with ytterbium fiber case because there are fewer high order modes.



a) 12.5um flat

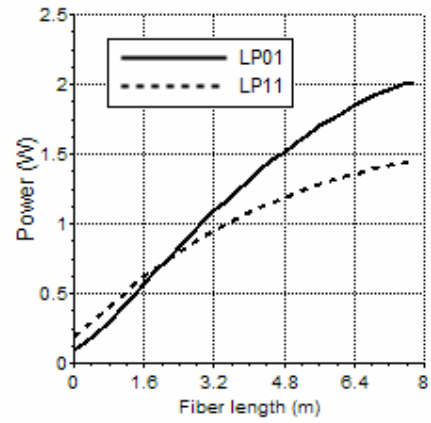

b) 10um flat

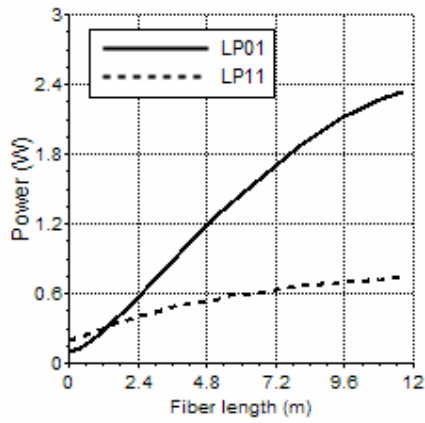

c) 7.5um flat

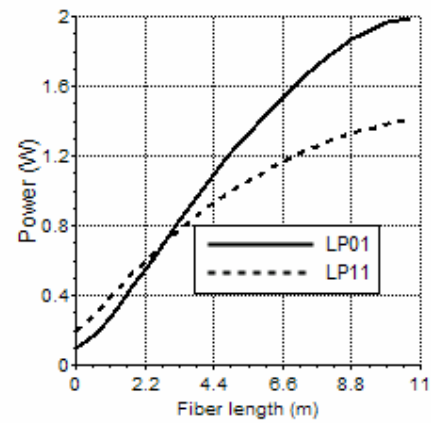

d) 12.5um flat

Figure 6: Signal modes propagation in the erbium doped fiber with various dopant distributions

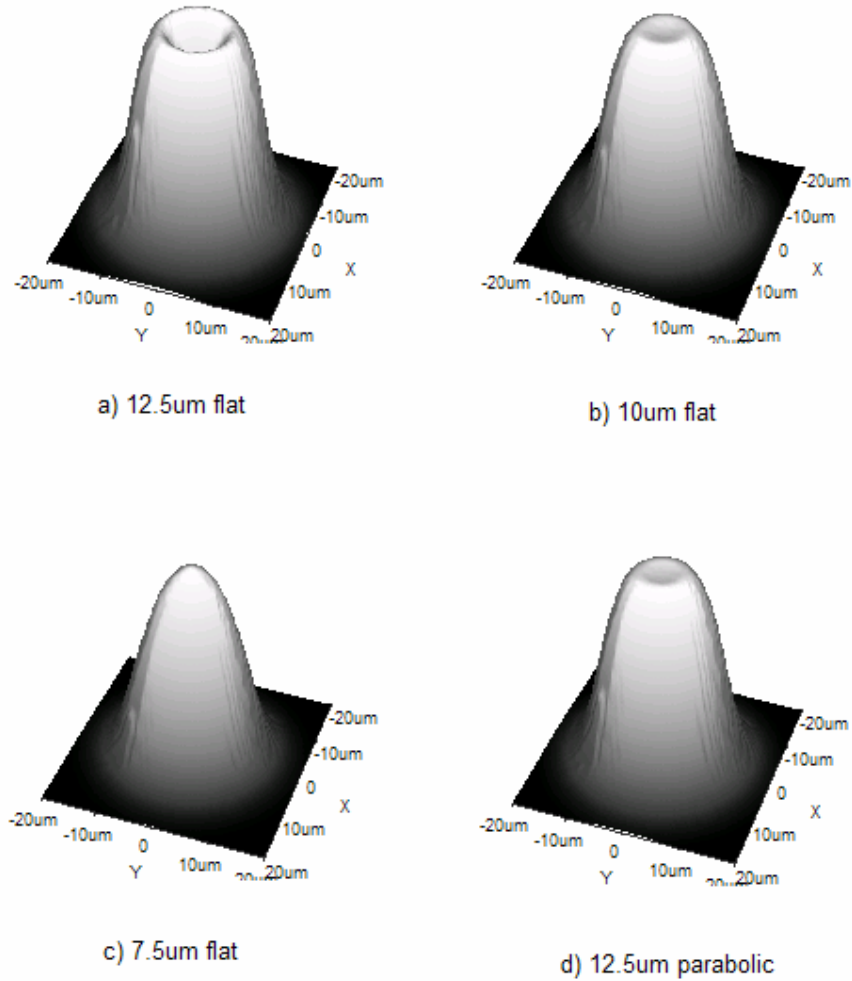

Figure 7: Profiles of the output beams for the erbium doped fiber

Conclusions

Large mode area fibers that are necessary in high power applications frequently support multiple high order modes. Even in the case where a relatively low number of high order modes (2 to 4) are supported, the beam quality of the output beam can be significantly degraded. One way to reduce the power in the higher order modes is to radially control the distribution of the rare earth dopant concentration. In this paper, we have used Liekki Application Designer v3.1 to simulate the propagation of all supported modes of the doped fiber in a seeded amplifier and have obtained the output power distribution among the modes and the near-field spatial profile of the output beam.

We have shown that a dopant confinement reduces significantly the output power in higher order modes.

The confinement requires longer fiber length and/or higher dopant concentration. Parabolic doping may provide a good compromise, providing relatively good high order mode suppression for reasonable fiber length. Further tuning the doping profile and concentration can optimize the mode suppression.

Acknowledgements

Special thanks to Roger L. Farrow from Sandia National Laboratories for very fruitful discussions and support in testing the simulator.

References

1. D. Marcuse, Theory of dielectric optical waveguides, Academic Press, 1974/1991